



Cement Mixer

Digga Cement Mixer can mix anything from cement to fertilizer, it fits quickly and easily to your Digga Planetary Auger Drive (Auger Drive sold separately)

Features:

- Easy Connection. Simply pin cradle to existing auger frame and add mixer bowl. Change from drilling to mixing in under 2 minutes.
- Cement mixing attachment to suits Digga auger drives and frames only. Also available for mini machines.
- Maintenance free.
- Manufactured from quality materials.

Ideal Use:

Mixing cement, mulch, animal feed, fertilizer.

Machine Suitability:

Skid Steer Loaders, Front End Loaders and Tele-Handlers.

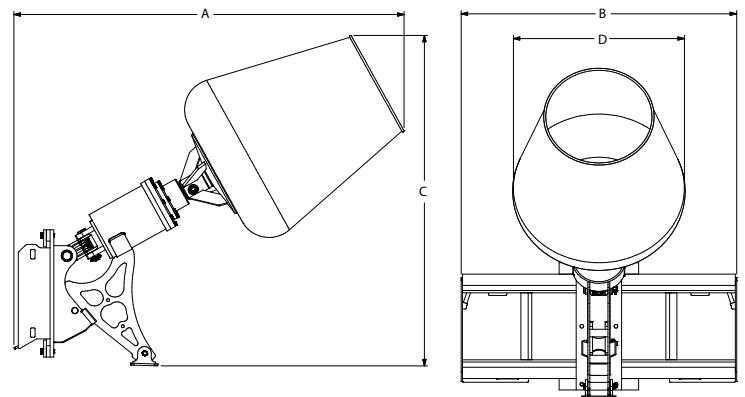

Specifications	Small	Large
Total Capacity ^	3.9 Cu ft / 110 L	5.7 Cu ft / 160 L
Operating Capacity *	2.5 Cu ft / 70 L	4 Cu ft / 115 L
Length (A)	1300 mm	1424 mm
Width (B)	1212 mm	1212 mm
Height (C)	1469 mm	1571 mm
Width (D) Bowl Only	580 mm	740 mm
Weight Complete with PD3 & Frame	158 kg	173 kg
Weight (Bowl & Cradle Only)	38 kg	53 kg

(*) Maximum operating capacity is measured at an operating angle of 45 degrees.

(^) An upright position depicts total capacity.

Contact your local professional dealer or contact Digga direct

THE BEST DOWNUNDER

DIGGA

PHONE: 1300 2 DIGGA EMAIL: info@digga.com WEB: www.digga.com

QLD, NT
4 Octal Street
Yatala QLD 4207

NSW, ACT
Unit 2, 36 Bluett Drive
Smeaton Grange NSW 2567

VIC, SA, TAS
27 Metcalf Street
Dandenong VIC 3175

WA
6/15 Yampi Way
Willeton WA 6155



AUTHORISED
DIGGA DEALER